

G5201T

InHome

G.hn Wave2 bridge with 2.5GE LAN port
for home network via telephone cables

User manual

Version 1.1
April 2026

For further information and purchase inquiries,
please contact info@gigacopper.net

2. Scope of delivery

- G5201T Bridge
- DC-12V/1A power adapter
- Bracket for wall mounting
- 1,5m RJ11/RJ11 telephone cable, 4-pole (SISO and MIMO)
- 1,5m LAN cable

3. Technical specifications

- Dimensions: 110x25x83mm
- Weight: 0,19kg
- Operating temperature: 0°C - 40°C
- Power consumption: <3W

4. G.hn specification

- G.hn Wave2, SISO: 2-200MHz, MIMO: 2x 2-100MHz
- Physical bandwidth (PHY): ca. 1800Mbit/s
- Net bandwidth: ca. 1500Mbit/s
- Max. attenuation of the cable connection: 75dB

1. Introduction

With the G.hn Wave2 Bridge G5201T, you can easily extend your **local Ethernet network** using existing telephone cables.

The modems are “multipoint” capable: up to 16 devices can be used in the telephone cabling. Each modem in the G.hn network communicates directly with all the others (“peer-to-peer”).

Any type of telephone cable can be used for data transmission. The bandwidth is up to approx. 1500Mbit/s. When the G.hn network is not heavily used, each modem can claim the transmission time for itself and transmit data to other modems at full bandwidth. When several modems are active, the transmission time and thus the bandwidth is automatically shared.

The G5201T bridge is compatible with other GIGA Copper G.hn Wave2 InHome telephone modems (see point 7); they can be combined as desired.

The G5201T bridge is also suitable for **forwarding a fiber optic connection from the ONT to the router** via existing telephone lines in **single-family homes**. This requires two modems.

5. Connections and LED indicators



Rear	
DC 12V	Power supply (12V, max. 1A)
RST	Recessed Reset button (15 sec. to hold)
LED on/off	On/Off all LED on the front
LINE	Connection between modems
2.5GE	2,5 Gigabit Ethernet Port
Front	
PWR LED	Indicates power availability
LINE LED	State of G.hn connection: Off – no connection Green – connection active Green flashing – data transmission
2.5GE LED	State of Ethernet connection: Blue – 2,5Gbit/s (2500Mbit/s) Green – 10/100/1000Mbit/s Blue/blue flashing – data transmission

6. Data connection bandwidth and 2.5GE port on the modem

According to the G.hn Wave2 standard, the net bandwidth of the data connection at the application level is approximately 1,5 Gbit/s. Due to **2.5GE LAN port**, the G5201T bridge can fully utilize this bandwidth and **send and receive data at up to 1,5Gbit/s**. The bandwidth depends largely on the length of the cable connection (attenuation of the route, see point 10). The web interface of the G5201T bridge displays the negotiated bandwidths to all other modems in the network (see point 15).

7. Use for home networking (local network behind Internet router)

The G5201T bridge complies with the G.hn Wave2 specification and enables complete home networking or expansion of the local Ethernet network via the existing telephone cabling at Gigabit speed. Installation is based on the “plug-and-play” principle: the network is ready for use immediately after the modems have been connected.

Up to 16 modems can be used within the G.hn network. The G5201T bridge is compatible with the following GIGA Copper G.hn Wave2 InHome telephone modems; all models can be combined as desired:

- G5204T (1x 2,5 Gigabit + 3x Gigabit LAN port and 1x analog telephone)
- G4201TM (1x Gigabit LAN port) ¹
- G4202T (2x Gigabit LAN port and 1x analog telephone) ¹
- G4202TCP (2x Gigabit LAN port with PoE/PoE+) ¹
- G4204T-W (4x Gigabit LAN port and WiFi 5) ¹

¹ The device supports the G.hn profile “PHONE 200MHz” (see point 9). The G5201T bridge must also use this profile; this is its factory setting.

Terminal devices with Ethernet interfaces can be connected to the modems' LAN ports: PCs, printers, WLAN repeaters, etc.

Heimvernetzung über Telefonkabel mit G.hn

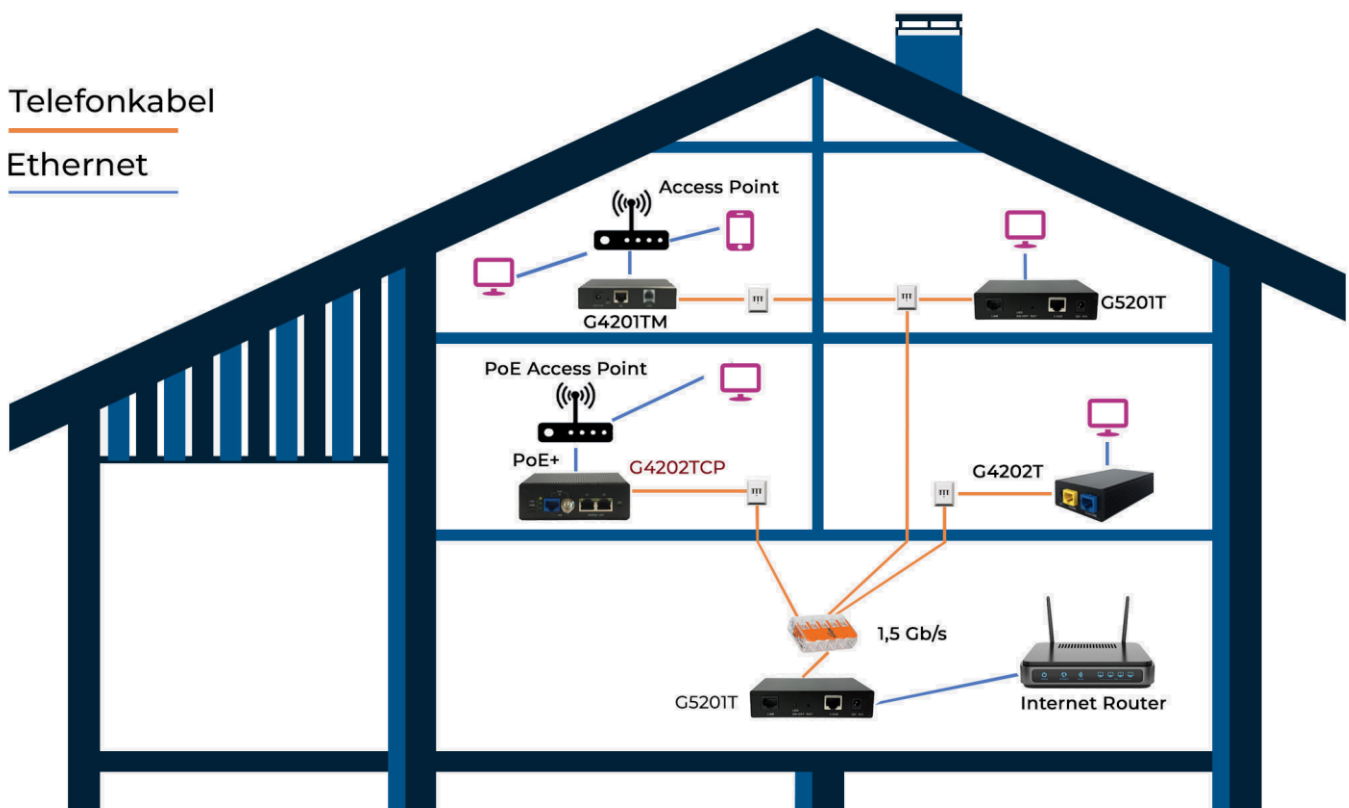

8. Use for forwarding a fiber optic connection (connection ONT -> Router)

The G5201T bridge can be used to forward a fiber optic connection from the ONT (fiber optic modem) to the internet router single-family homes. This requires two G5201T modems:

Weiterleitung eines Glasfaser Anschlusses in einem Einfamilienhaus

Telefonkabel

Ethernet

Glasfaser

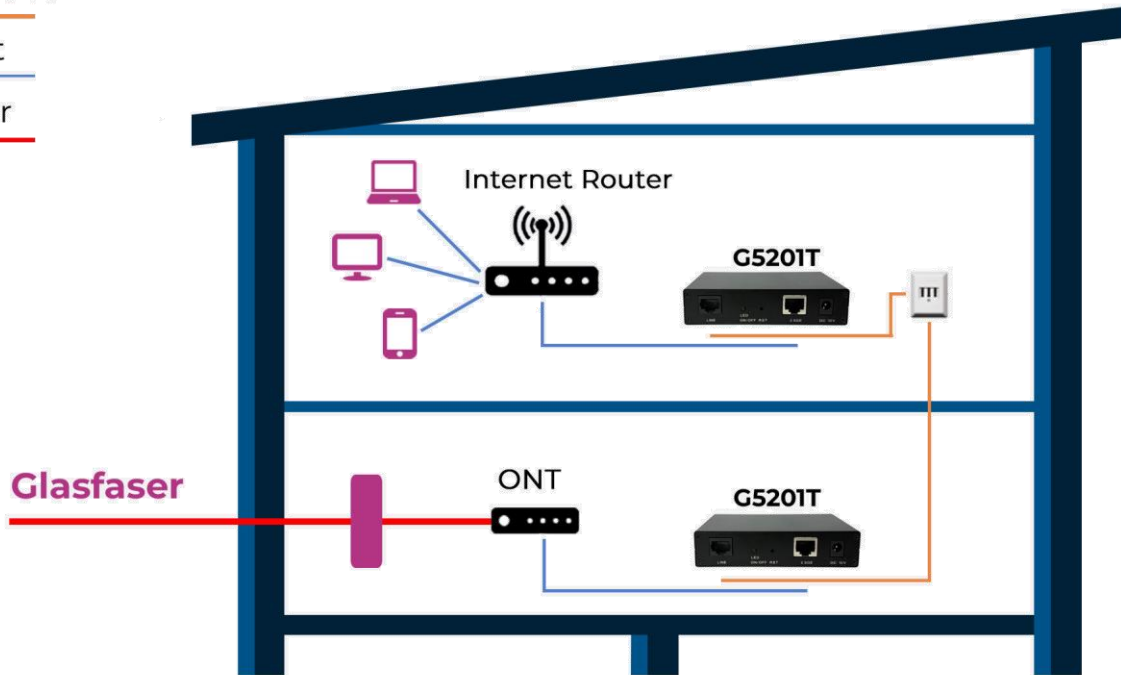

Note on IPv4 configuration:

DHCP client is enabled in the factory settings of the G5201T bridge. Disable the DHCP client before connecting the modem to the ONT so that it does not receive an IP address from the Internet provider. To do this, log in to the modem's web interface (see section 14.2), set "IP / DHCP enabled" to "NO" in the menu, enter an IPv4 address from a private range (e.g., 192.168.9.252, subnet mask 255.255.255.0, default gateway 192.168.9.1, DNS 192.168.9.1) and confirm your entry with OK. Repeat this configuration in the second modem.

IPv4 configuration*	
DHCP enabled	NO <input type="button" value="v"/>
IPv4 address / netmask	<input type="text" value="192.168.9.252"/> / <input type="text" value="255.255.255.0"/>
Default Gateway	<input type="text" value="192.168.9.1"/>
DNS	<input type="text" value="192.168.9.1"/>
Additional address #1	<input type="text" value="192.168.10.253"/> / <input type="text" value="255.255.255.0"/>
Additional address #2	<input type="text" value="0.0.0.0"/> / <input type="text" value="0.0.0.0"/>
*All changes except the DNS server will have effect after system boot	
<input type="button" value="Ok"/> <input type="button" value="Cancel"/>	

9. G.hn profile

The G.hn Wave2 standard defines data transmission via any type of telephone and coaxial cable. However, in direct comparison with coaxial cables, telephone cables have significantly higher attenuation, which limits the bandwidth for very long cables and the possible cable length. To increase this, G.hn technology provides for MIMO (4-wire) operation via telephone cables in addition to SISO (2-wire) operation.

- G.hn profile „PHONE 200MHz“: One data channel 2-200MHz
- G.hn profile „PHONE 100MHz MIMO“: Two data channels 2-100MHz

The choice of G.hn profile has no effect on the stability of the connection; the maximum bandwidth of approx. 1.5 Gbit/s remains the same. By not using the higher frequencies of 100-200 MHz, which are subject to higher attenuation with increasing cable length for physical reasons, a higher bandwidth can be achieved in MIMO mode above a certain cable length, and the maximum possible distance also increases (see point 10).

The G5201T bridge supports both G.hn profiles. The SISO profile “PHONE 200MHz” is configured in the factory settings, and data is transmitted via a pair of wires. This profile is sufficient for home networking in “typical” single-family homes, as the cable lengths are usually not very long. To use the “PHONE 100MHz MIMO” profile, the G.hn profile setting must be changed in the web interface of each modem in the network and two wire pairs must be connected to each modem (see point 11).

10. Data connection range

The G5201T bridge uses a very powerful G.hn chipset: up to approx. 35dB attenuation, a net bandwidth of approx. 1500Mbps is achieved, at 50dB – approx. 1Gbps, at 75dB – still approx. 100Mbps.

There are various types of cables with different attenuation values on the market. The following graphs show the bandwidth achievable in practice for common telephone cable types in Germany in SISO and MIMO operation (2-/4-wire):

- Telephone cables for indoor wiring: J-Y(St)Y, J-YY und J-2Y(St)Y.
- Telephone cables for outdoor wiring: A-2Y(L)2Y und A-02Y(L)2Y underground cable. Air cables have similar properties.

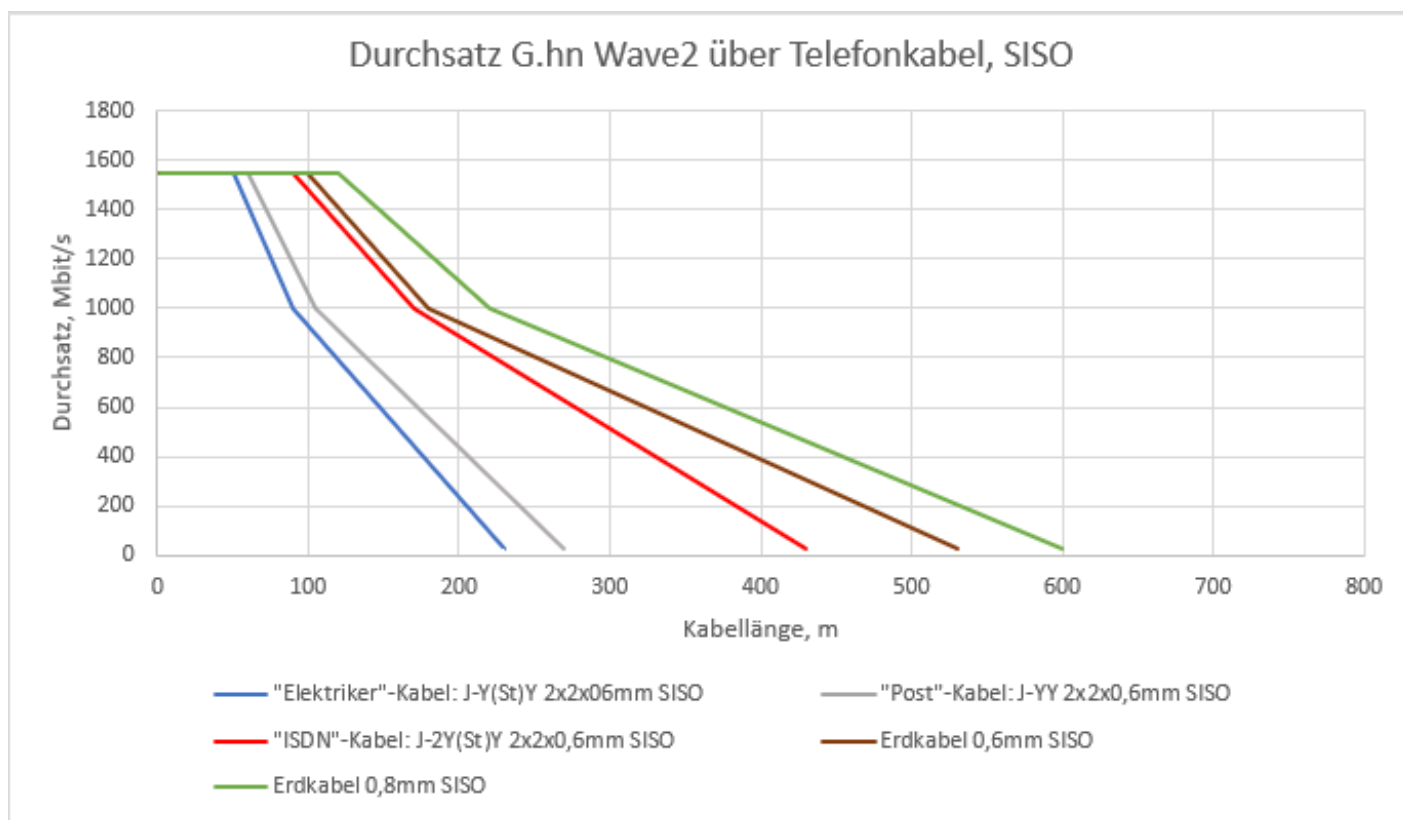

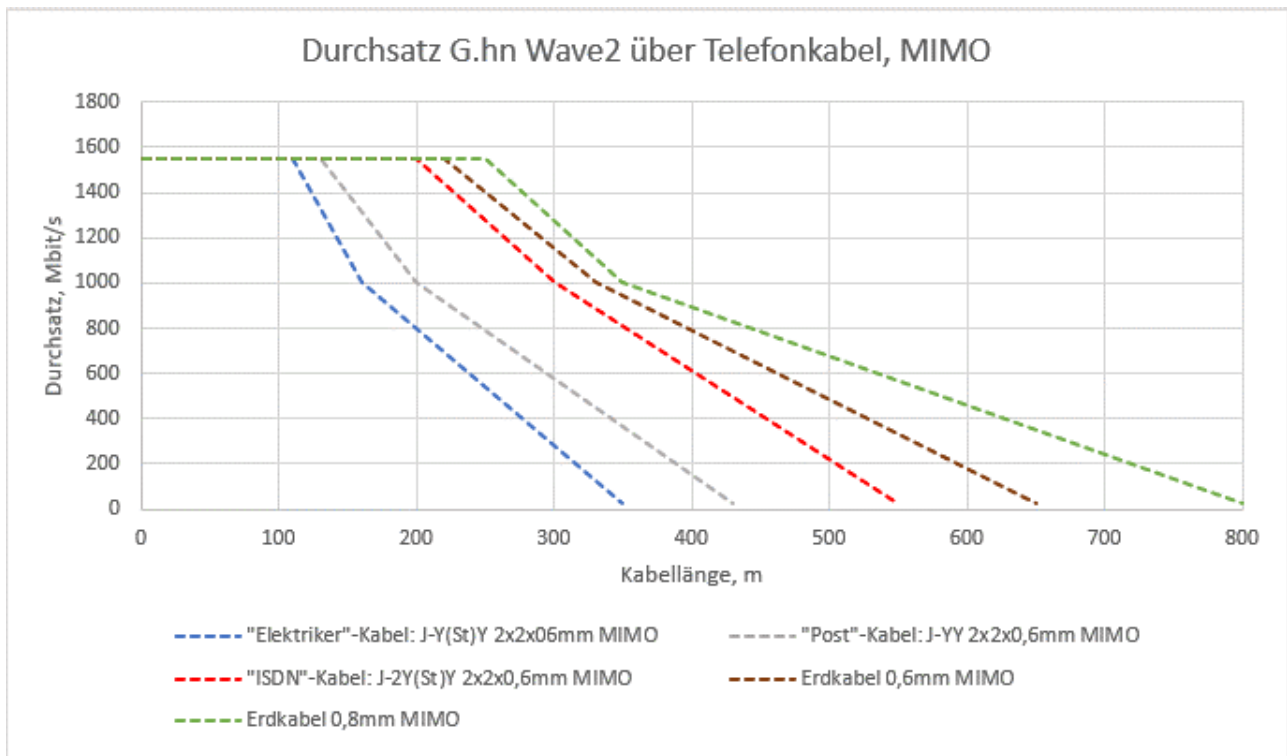

11. Wire assignment on the device (combined RJ11/RJ45 plug)

SISO pin assignment: one data channel



MIMO pin assignment: two data channels

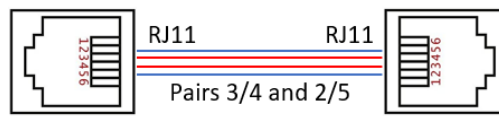

The LINE connection on the device is also suitable for data cables with 8-pin RJ45 Western connectors. Pin assignment SISO: 4/5, pin assignment MIMO: 4/5 and 3/6.

The wires of same data channel can be connected straight or crossed.

12. Parallel operation with analog telephony

The G5201T bridge uses frequencies between 2 and 200 MHz for data transmission in accordance with the G.hn Wave2 standard. Analog and ISDN telephony, on the other hand, only require a few kHz in the lower frequency range. This means that the two signals do not interfere with each other on neighboring telephone lines. In addition, parallel operation of G.hn and analog telephone signals on one twisted pair is possible. An external DSL splitter is required to combine the G.hn data signal from the G5201T bridge with an analog telephone signal.

13. Connection between modems in “star” and “daisy chain” configurations of telephone cables

The G.hn network can include up to 16 modems. The G5201T bridge can be used with all types of cabling: star, daisy chain, or a combination of both.

In order for the modems to communicate with each other across different cable strands, the telephone cables must be connected together (two or four wires). Cable clamps or RJ45 splitters can be used to connect telephone cables laid in a “star” configuration. When the modems are connected in series, the telephone cables are connected directly within sockets.

Further detailed information and installation tips can be found on our website www.gigacopper.net under “Support and Advice”

14. Login to the web interface

You log in to the modem's web interface using its IP address and password. Factory settings:

Password: paterna

IP addresses:

- First IP address: DHCPv4 client is enabled, the modem obtains this IP address from the local DHCP server.
- Second IP address: 192.168.10.253

14.1 Accessing the modem via local network

- Connect the modem to your network. The modem will receive an IP address from the local DHCP server (usually the Internet router).
- Open a web browser on your computer and connect to the modem's IP address. You can find the assigned address in the administration section of your DHCP server.

14.2 Direct access to the modem

- Connect your computer to the 2.5GE port on the modem.
- Assign your computer a fixed IP address from the range 192.168.10.xxx: e.g., 192.168.10.100. Use 255.255.255.0 as the netmask. It is not necessary to enter the default gateway and DNS serv.
- Open a web browser and connect to the modem via its second IP address 192.168.10.253

15. Query of the negotiated bandwidth

The bandwidths negotiated between a G.hn bridge and all other modems in the network can be queried via the web interface. The values displayed are gross transmission rates in Mbits/s on the physical layer (PHY) in the transmit and receive directions. The net transmission rate at the application level is approximately 17% lower.



G5201T Web Configuration

Log Out

- [G.hn](#)
- [IP](#)
- [Ethernet](#)
- [Device](#)
- [Multicast](#)
- [QoS](#)
- [G.hn spectrum](#)
- [Advanced](#)

Basic settings

- MAC address fc:e4:98:b0:00:90
 - Device ID 3
 - Domain Name
 - Force node Type AUTOMATIC ▾
 - Node type* END_POINT
- * Node type change can take some time, please refresh page to update state

Ok Cancel

- G.hn profile PHONE 200MHZ ▾

Ok Cancel

Available Connections

Device ID	MAC Address	Phy Tx (Mbps)	Phy Rx (Mbps)
1	fc:e4:98:b0:01:44	1862	1835
2	fc:e4:98:b2:00:29	1836	1807

16. Use of multicast IP TV

For the transmission of multicast IP TV in the local network, "IGMP snooping" must be enabled in the multicast configuration.

Multicast Configuration*

- IGMP Snooping: YES
- MLD snooping: NO
- IGMP/MLD broadcast report: NO
- IGMP/MLD broadcast report mode: 0
- Filter unknown multicast traffic: NO
- IGMP Multicast ranges:

Minimum IP address			Maximum IP address		
224	0	0.0	239	254	.255.255
0	0	0.0	0	0	.255.255
0	0	0.0	0	0	.255.255
0	0	0.0	0	0	.255.255

Ok Cancel

Broadcast suppression

- Broadcast xput limit (Mbps): 2

Ok Cancel

17. VLAN usage in the network

The modems are compatible with VLANs according to the 802.1Q standard. The VLAN tags are forwarded transparently. External Ethernet switches must be used to create VLANs.

18. Notching, compatibility with DSL/VDSL

G.hn modems can be used in parallel with DSL/VDSL connections, even with unshielded telephone cables and via twisted pairs of a shared cable.

In the case of ADSL/ADSL2, no settings are required in G.hn modems, as the frequency ranges of ADSL/ADSL2 and G.hn do not overlap.

In the case of VDSL50, no settings are usually required in G.hn modems either, as VDSL50 has a significantly higher signal level.

For compatibility with VDSL100 (profile 17a) and VDSL250 (profile 35b), the G.hn level in the 2-17MHz or 2-35MHz range must generally be reduced by 10dB. If necessary, higher attenuation can be configured (up to 40dB) or the range can be completely blocked (100dB attenuation). The setting must be configured in each modem in the network.

Notches Configuration

Notch index	Start freq (KHz)	Stop freq (KHz)	Depth (dB)	Type
0 0	1954	100	Regulation	

Add new user notch

- Index (0..9):
- Start frequency (KHz):
- Stop frequency (KHz):
- Depth (0..40dB, 100 removes notch):

Ok Cancel

Remove user notch

- Index (0..9):

Ok Cancel

19. Wall mounting

There are four screws in the corners on the back of the device. To attach the brackets for wall mounting, first loosen the screws on one side, position the bracket, and secure it with these screws or the replacement screws provided. Repeat the step on the other side.

20. Warranty

We provide a 12-month warranty on all GIGA Copper Networks brand products purchased from us. Full warranty terms and conditions can be found at <https://www.gigacopper.net/wp/en/warranty/>